

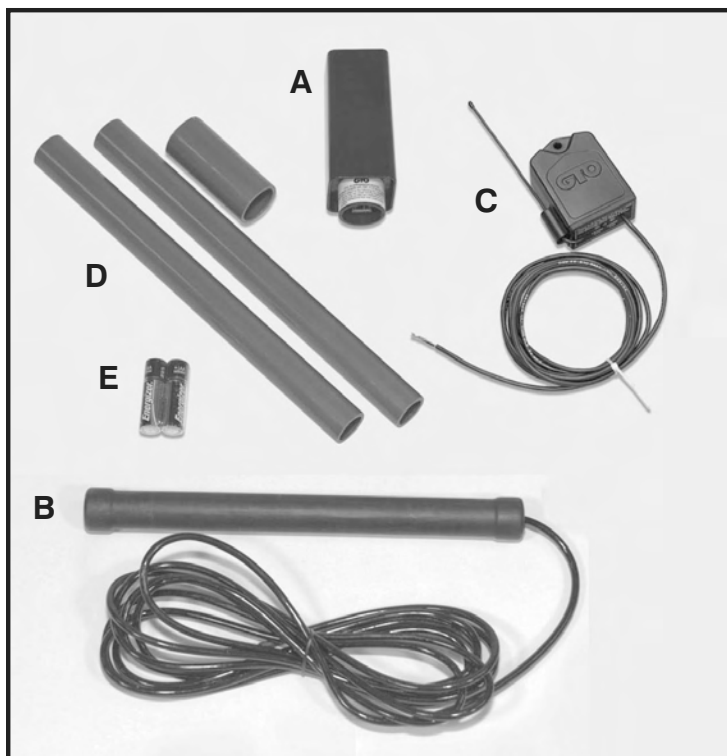

Know what's below.
Call before you dig.



Wireless Vehicle Sensor Installation Manual



Kit Includes:

- A. Transmitter Module/Cover
- B. Sensor/Sensor Cable
- C. Receiver (RB709U-NB required for some gate openers)
- D. Mounting Post (3 pieces)
- E. 2 "AA" Batteries (*Note: lithium-alkaline batteries are recommended for extreme cold climates.*)

How it Works:

The electromagnetic sensor detects vehicles in motion and automatically activates your gate. This "hands free" device allows friends, family, and delivery personnel to exit your property without the need of an Entry Transmitter, or you, to operate the gate.

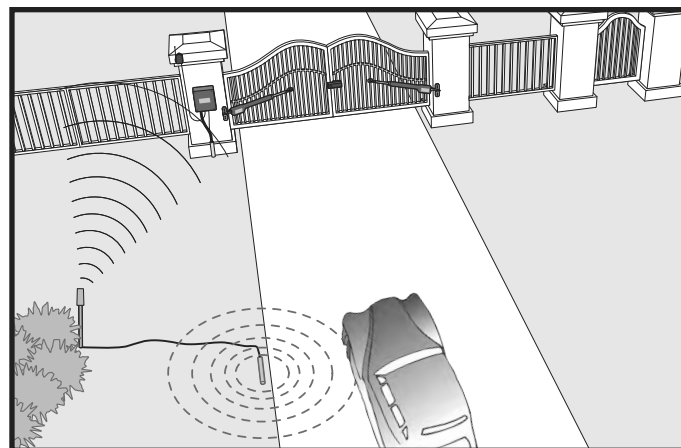

When a VEHICLE SENSOR is in use, the automatic gate opener could be activated by a child on a bicycle, tricycle, or other metal play equipment. DO NOT ALLOW UNATTENDED CHILDREN OR PETS NEAR YOUR AUTOMATED GATE AT ANY TIME.



This product and any accessory you purchase should only be installed on a gate opener that meets the current UL325 safety standard. If you have a gate opener that is not listed with the current standard, please contact the GTO sales department for consultation on a gate opener that can meet your specific needs.

FCC WARNING: Changes or modifications to this unit not expressly approved by the party responsible for compliance could void the user's authority to operate the equipment.

NOTE: This equipment has been tested and found to comply with the limits for a Class B digital device, pursuant to Part 15 of the FCC Rules. These limits are designed to provide reasonable protection against harmful interference in a residential installation. This equipment generates, uses and can radiate radio frequency energy and, if not installed and used in accordance with the instructions, may cause harmful interference to radio communications.

However, there is no guarantee that interference will not occur in particular installations. If this equipment does cause harmful interference to radio or television reception, which can be determined by turning the equipment off and on, the user is encouraged to try to correct the interference by one or more of the following measures: • Reorient or replace the receiver antenna. • Increase the separation between the equipment and the receiver. • Connect the equipment into an outlet on a circuit different from that to which the receiver is connected. • Consult the dealer or an experienced radio/TV technician for help.

GTO Limited One Year Warranty

Gates That Open, LLC (GTO), gate openers and accessories are covered under warranty by the manufacturer against defects in materials and manufacturer workmanship for a period of one (1) year from date of purchase, *provided the recommended installation procedures have been followed.*

In the case of product failure due to defective material or manufacturer workmanship within the one (1) year warranty period, the product will be repaired or replaced (at the manufacturer's option) at no charge to the customer, if returned freight prepaid to GTO, 3121 Hartsfield Road, Tallahassee, Florida, USA 32303. **IMPORTANT: Call (800) 543-1236 for a Return Goods Authorization (RGA) number before returning accessory to factory.** Products received at the factory without an RGA number will not be accepted. Replacement or repaired parts are covered by this warranty for the remainder of the one (1) year warranty period or six (6) months, whichever is greater. GTO will pay the shipping charges (equal to United Parcel Service GROUND rate) for return to the owner of items repaired under warranty.

The manufacturer will not be responsible for any charges or damages incurred in the removal of the defective parts for repair, or for the reinstallation of those parts after repair. This warranty shall be considered void if damage to the product(s) was due to improper installation or use, connection to an improper power source, or if damage was caused by electrical power surge or lightning, wind, fire, flood, insects or other natural agent.

After the one (1) year warranty period, GTO will make any necessary repairs for a nominal fee. Call GTO at (800) 543-1236 for more information. This warranty gives you specific legal rights, and you may also have other rights which may vary from state to state. This warranty is in lieu of all other warranties, expressed or implied. **NOTE: Verification of the warranty period requires copies of receipts or other proof of purchase. Please retain these records.**

Gates That Open, LLC

3121 Hartsfield Road • Tallahassee, Florida 32303

Sales: 1-800-543-GATE (4283) • Technical Support: 1-800-543-1236

www.gtoinc.com

Technical Support Hours: MON-FRI, 8:00 a.m.-7:00 p.m. (ET)

800/543-1236 • 850/575-4144

1. Program DIP Switch Settings

Step 1: Remove the cover from your gate opener Entry Transmitter. Remove the cover from the Transmitter Module.

Step 2: You will change the DIP Switch settings on the Transmitter Module to match those of your Entry Transmitter.

For **Single Button** Entry Transmitters, set the 9 DIP Switch settings on the Transmitter Module to match the 9 DIP Switch settings of the Entry Transmitter.

For **Dual Button** Entry Transmitters, set the first 8 DIP Switch settings on the Transmitter Module to match the 8 DIP Switch settings of the Entry Transmitter. The 9th DIP Switch setting (Transmitter Module) will depend on which button you use to operate the gate (see illustration).

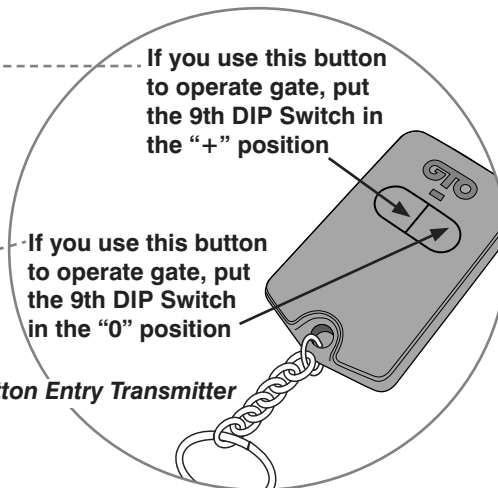
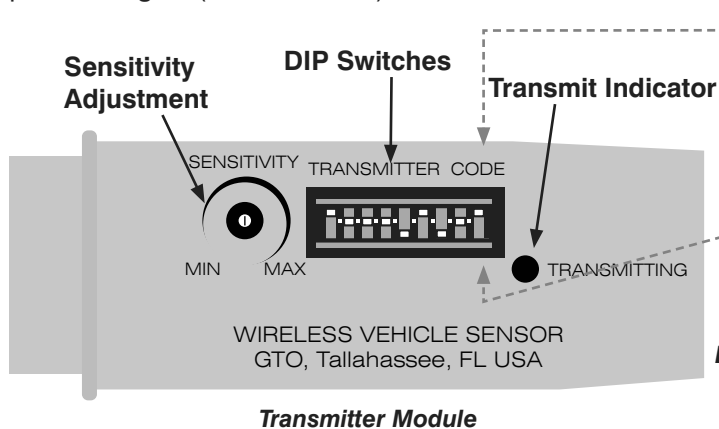
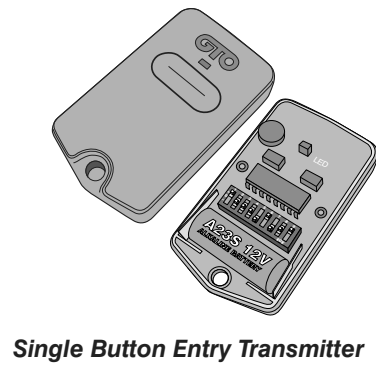
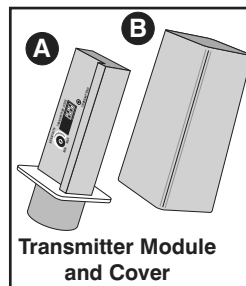

2. Determine Location for Sensor and Transmitter Module

NOTE: Install Transmitter Module and Sensor on the same side of the driveway as your automatic gate opener/receiver.

Placement of SENSOR:

- No more than 2 ft. from edge of driveway.
- At least 25 ft. from leading edge of open gate, roadways, neighboring driveways, etc.
- Parallel to direction of the driveway.

Placement of TRANSMITTER MODULE:

- No more than 15 ft. from Sensor.
- No more than 100 ft. from gate opener receiver.
- Within "line of sight" of the gate opener receiver.
- Away from lawn sprinklers (Transmitter Module is water resistant, not waterproof).
- Away from the driveway edge so that vehicles are unlikely to hit it.

For Optimum Performance:

- Install the Sensor as far away as possible from power transformers, power lines, underground gas lines, and telephone lines.
- Locate the Sensor away from general moving traffic to prevent unwanted activation (the Sensor detects magnetic disturbances caused by a vehicle's mass and velocity).
- It is recommended that you run the Sensor Cable inside PVC conduit to prevent accidental damage.
- Do not run Sensor Cable in conduit with other wires such as AC power or other control wires.
- THE SENSOR CABLE MUST NOT BE SPLICED.

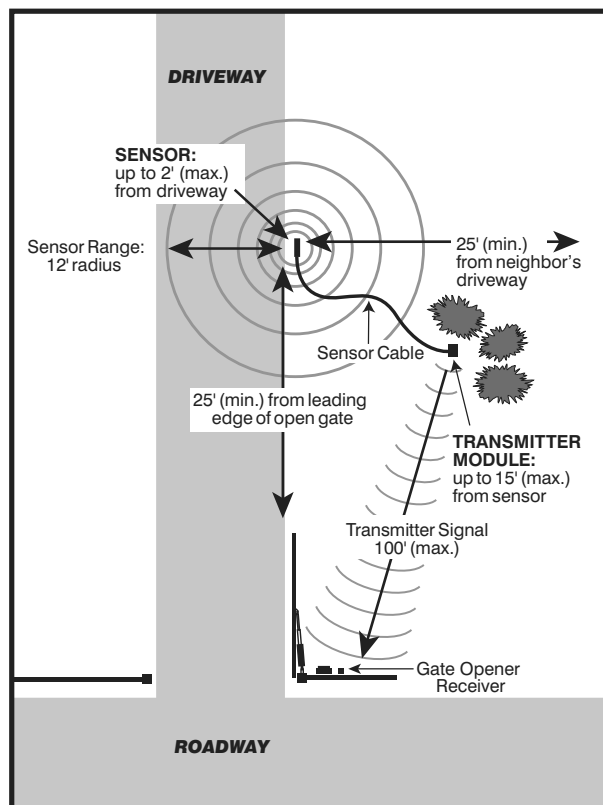

Sensor Range distance is approximate and will vary due to outside interference, vehicle mass, speed, etc.

3. Install Sensor and Transmitter Module

IMPORTANT: Clear an area 25 ft. in all directions of metal tools, toys, and automobiles to prevent magnetic disturbance during testing and installation.

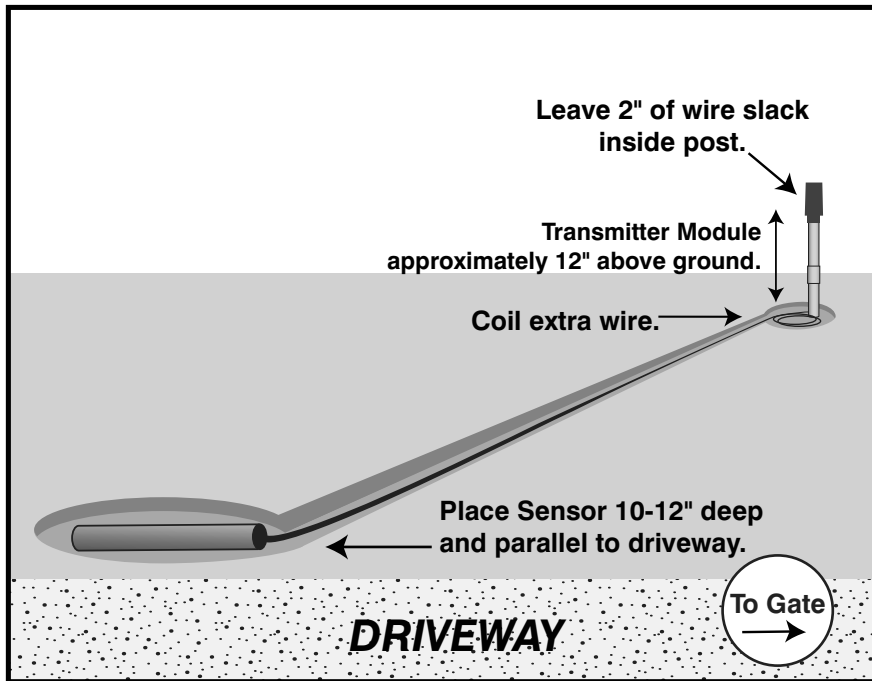

Step 1: Dig a hole for the Sensor, 10–12 in. deep and 24 in. long. Be sure the hole is parallel to the direction of the driveway and not more than 2 ft. away from the driveway.

Step 2: Dig a trench in which to lay the Sensor Cable from this hole to where you will install the Transmitter Module (15 ft. maximum distance). The trench should be at least 6 in. deep to prevent possible wire damage from edgers, lawn aerators, etc.

Step 3: Lay the Sensor in the hole parallel to the driveway and the Sensor Cable in the trench. Do not fill/cover the hole or trench until the Transmitter Module signal has been tested (page 3). *If you don't use the full 15 ft. of Sensor Cable, coil the extra cable beside the Mounting Post.*

Step 4: Assemble the Mounting Post using the coupler to connect the two longer pieces.

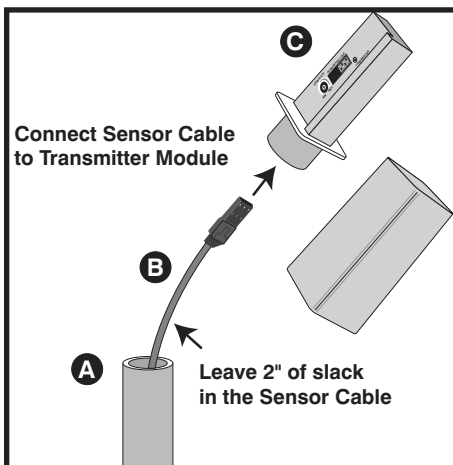

Step 5: Run the Sensor Cable (**B**) through the Mounting Post (**A**) and plug it into the connector at the bottom of the Transmitter Module (**C**). Allow 2 in. slack in the cable to prevent damage to the connector if Transmitter Module is removed.

Step 6: Attach the Transmitter Module to the Mounting Post. At this point, you can put the Mounting Post in the ground, but don't fill the hole until after testing (page 3).

Do You Need to Install the Receiver?



IMPORTANT: The RB709U-NB Universal Receiver (included) is designed, and necessary, to work with certain models of GTO/Mighty Mule Gate Opener control boards. **Many models do not require the use of the Receiver.** To determine if you will need to install the Receiver, remove the gate opener control box cover and examine the control board.

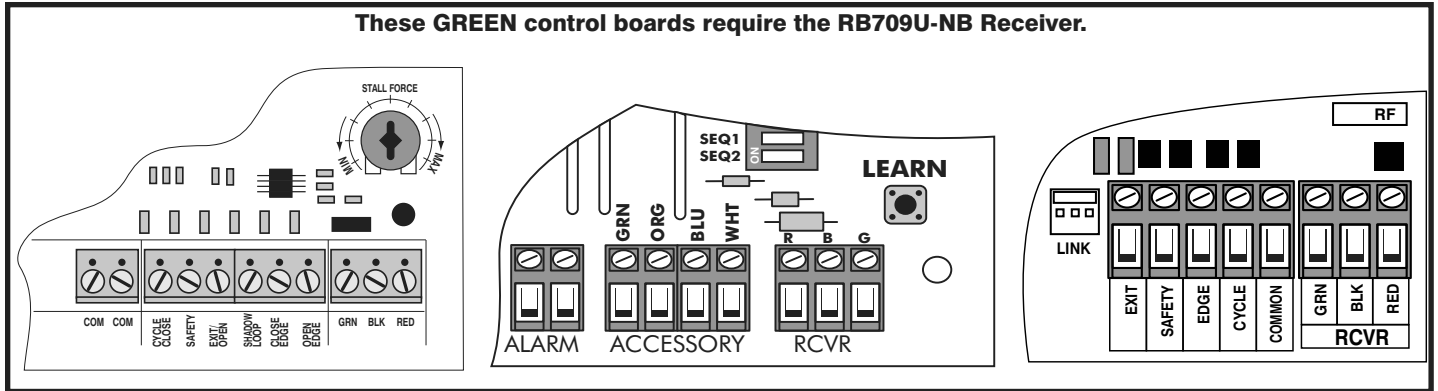

If your control board matches any of the illustrations above, you **WILL** need to install the Receiver (refer to the instructions on page 4).

If your control board **DOES NOT** match any of the illustrations above, proceed to #4 “Test the System.”

4. Test the System

Step 1: Make sure gate opener is turned ON and gate is in the closed position.

Step 2: Install 2 “AA” batteries (included) in the Transmitter Module; **the gate will open.** Wait 60 seconds before proceeding to the next step and **DO NOT move the sensor, any vehicles, or metal objects that are within 25 ft. during this calibration/“self-test” 60-second period.**

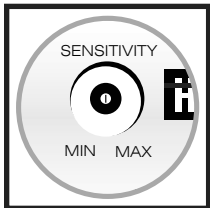

Step 3: Use your Entry Transmitter to close the gate. Test the Wireless Vehicle Sensor by driving your vehicle past the Sensor at normal driveway speed. The gate should open each time; if it does not, use a small screwdriver to increase the Sensitivity Adjustment (clockwise rotation).

Step 4: Once operation is satisfactory, turn the gate opener OFF. Fill the holes and trench with soil and tamp firm. The bottom third of the Mounting Post should be buried firmly in the ground.

Step 5: Turn the gate opener ON and make sure gate is in the closed position. Replace Transmitter Module cover and test the system again (Step 3). NOTE: Do not cover the Transmitter Module with anything metal, as this will cause signal interference.

Your installation is now complete. If your Wireless Vehicle Sensor is not working properly, please refer to the **Troubleshooting Guide** on the back cover of this Installation Manual.

Instructions for Installing the RB709U-NB Receiver



CAUTION: The “Learn” process may activate the gate. Please use caution when programming the Receiver.

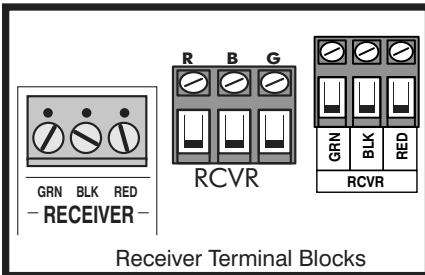

Step 1: The RB709U-NB will replace the gate opener receiver; disconnect the gate opener receiver’s RED, BLACK, and GREEN wires from the receiver terminals on the gate opener control board.

Step 2: Mount the RB709U-NB Receiver.

- The Receiver can be mounted up to 10 ft. from the gate opener control board.
- DO NOT mount the Receiver upside down.
- DO NOT mount on a metal surface (will reduce range).
- Run Receiver cable through PVC conduit to protect it from damage.
- DO NOT run Receiver cable in conduit containing AC wiring.
- Receiver range can vary depending upon weather, topography, and external interference.

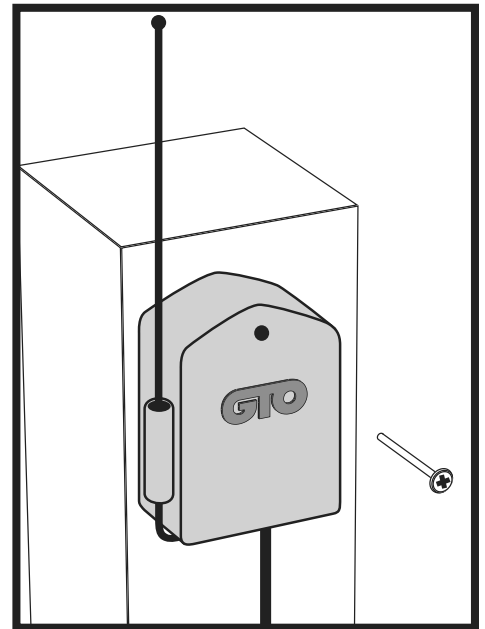

Step 3: Connect the RED and BLACK wires from the Receiver to the power supply (see illustration, page 5).

CAUTION: The “Learn” process may activate the gate. Please use caution when programming the Receiver.

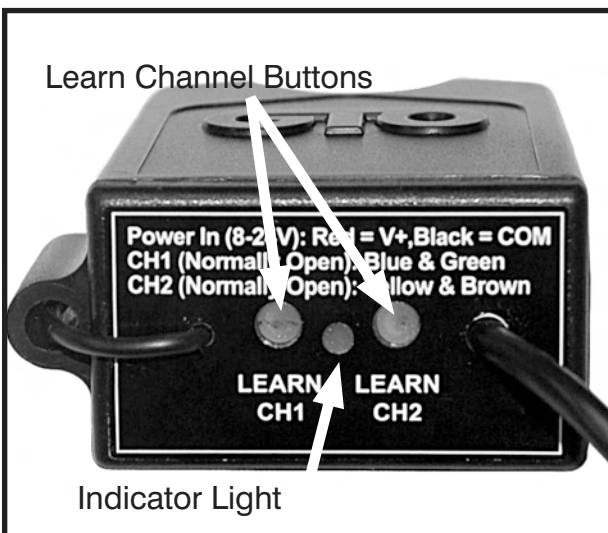

Note: You will have to use a small screwdriver or a pen to depress the LEARN CH buttons on the receiver.

Step 4: Connect the Receiver’s Channel 1 wires (GREEN and BLUE) to your control board (see illustration, page 5). Press and hold the Entry Transmitter button then the Receiver’s LEARN CH 1 button at the same time. The indicator light on the Receiver should blink once within 1–2 seconds to indicate that the Entry Transmitter setting is now programmed into the Receiver.

GREEN Control Boards

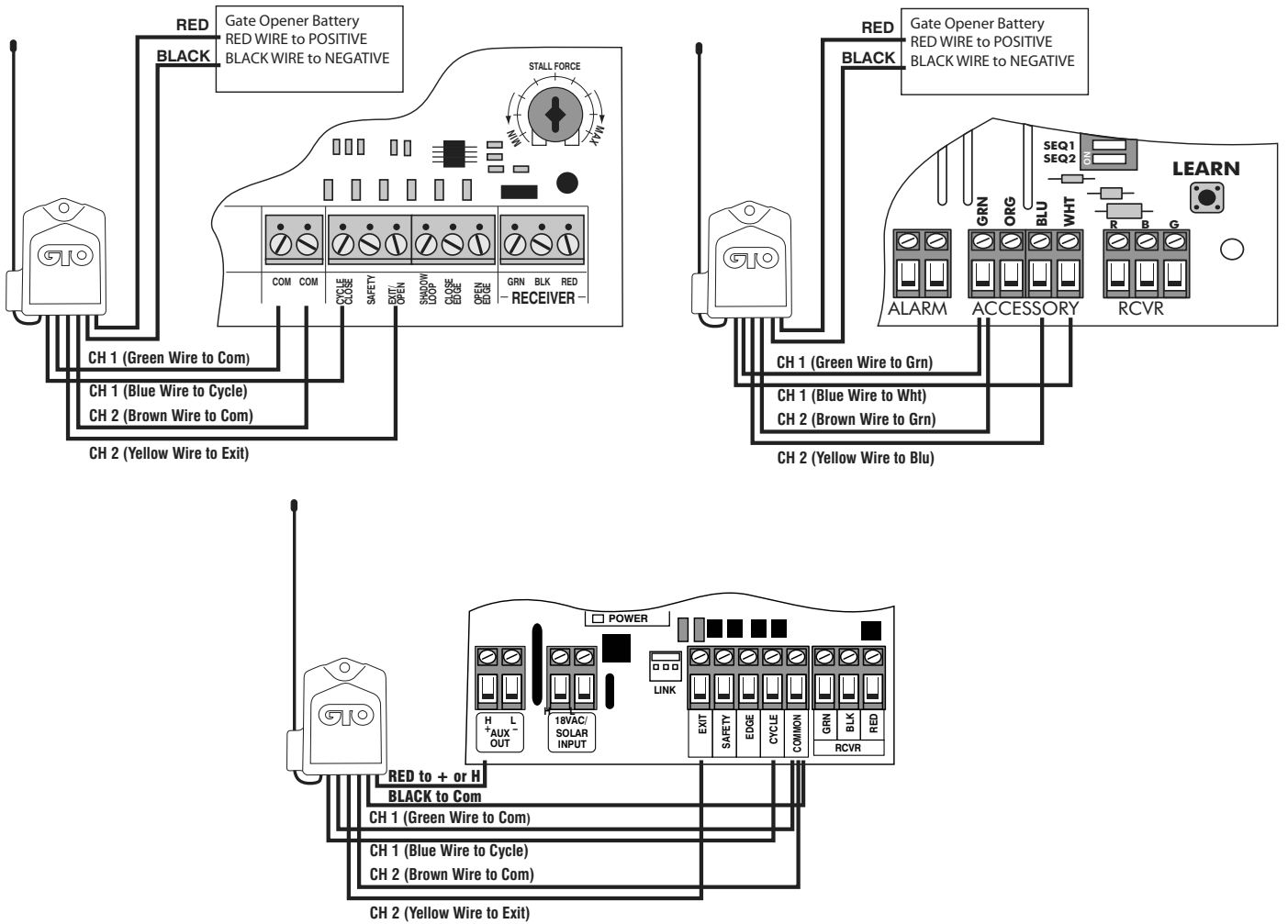

Step 5: Connect the Receiver’s Channel 2 wires (YELLOW and BROWN) to your control board (see illustration above). Have someone install the 2 “AA” batteries in the Transmitter Module: this will immediately start 30 seconds of transmission from the Wireless Vehicle Sensor. During transmission, you will press and hold the Receiver’s LEARN CH 2 button. The indicator light on the Receiver should blink twice within 1–2 seconds to indicate that the Wireless Vehicle Sensor setting is now programmed into the Receiver.

Step 6: Return to #4: “Test Your System” (page 3).

Troubleshooting Guide

If your Wireless Vehicle Sensor is not operating properly, please follow this checklist:

IMPORTANT: If you make any of the following adjustments, you will need to recalibrate the Transmitter Module before retesting (see page 3).

A. IF THE GATE IS NOT OPENING:

1. Check the batteries:
 - a. Verify batteries are installed correctly (align the “+” signs on the battery and in the battery compartment).
 - b. Verify batteries are working. Remove and reinstall the batteries. The Transmit Indicator on the Transmitter Module should blink for 30 seconds. If not, try installing a new pair of “AA” batteries.

NOTE: When reinstalling batteries, the system will need to recalibrate (page 3). Do not move any metal objects or the Transmitter Module for 60 seconds after reinstalling batteries.

2. Verify that the Sensor Cable is connected to the base of the Transmitter Module.
3. Increase the Sensitivity Adjustment on the Transmitter Module (page 3).
4. Verify that you have properly placed the Transmitter Module. Be sure it is installed:
 - on the same side of the driveway as the gate opener/receiver.
 - within 100 ft. and “line of sight” of the gate opener/receiver.
 - within 15 ft. of the Sensor.
 - 12 in. above ground level.
5. Verify that the Sensor is not more than 2 ft. from—and parallel to—the driveway edge.
6. If the RB709U-NB Receiver was installed:
 - a. Repeat the “learn” process (pages 4–5).
 - b. Verify that the Receiver is correctly wired to the gate opener control board (page 5):
 - c. Verify that the Receiver was mounted correctly (page 4):
 - not mounted upside down.
 - not mounted on a metal surface.
7. If the RB709U-NB Receiver was NOT installed:
 - a. Verify that the Transmitter Module DIP Switch settings were adjusted to match the Entry Transmitter’s DIP Switch settings (page 1).
 - b. Verify that the Entry Transmitter opens the gate. If not, you will need to program the Entry Transmitter’s settings into the gate opener receiver (see your gate opener Installation Manual), and then match the Transmitter Module’s DIP Switch settings with the Entry Transmitter.

B. IF THE GATE IS OPENING “ON ITS OWN”:

1. Verify that the Sensor is at least 25 ft. from the roadway and/or neighbors’ driveways.
2. Verify that there are no moving metal objects within a 25 ft. radius of the Sensor. (NOTE: in areas with high winds, metal objects such as flag poles/swing sets can trigger the Sensor if they are within range.)
3. Make sure Sensor Cable is not run in PVC conduit along with other AC or control wires.
4. Adjust the Sensitivity on the Transmitter Module (page 3).

The 24/7 Troubleshooting Wizard is available at <http://support.gtoinc.com>.
If you are unable to solve the problem, call the GTO Service Department at 1-800-543-1236.

Gates That Open, LLC
3121 Hartsfield Road • Tallahassee, Florida 32303
Sales: 1-800-543-GATE (4283) • Technical Support: 1-800-543-1236
www.gtoinc.com

Technical Support Hours: MON–FRI, 8:00 a.m.–7:00 p.m. (ET)

800/543-1236 • 850/575-4144